

REC PRO[®]



INSTRUCTION MANUAL

Gas Range

Models: RP-RANGE-17BL/RP-RANGE-17SS
RP-RANGE-21BL/RP-RANGE-21SS

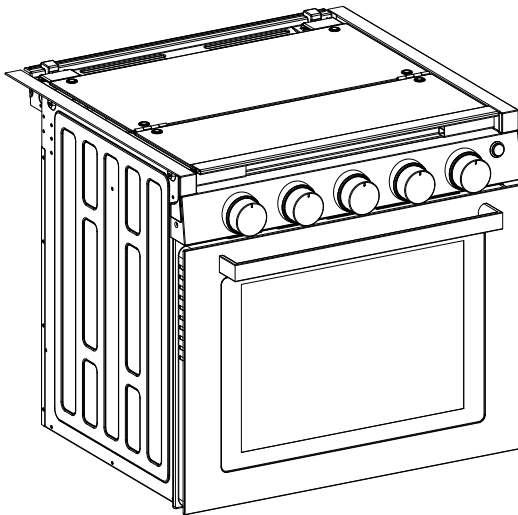

Table of Contents

Product Introduction.....	3
Safeguard Measures.....	4
Safeguard Preparations.....	5
Install Information.....	10
Functions.....	15
Range Features	21
Product Troubleshooting.....	22
Sanitation & Upkeep	23
Exploded-View Drawing.....	24
Product Warranty Information.....	26
Warranty Contact Information.....	28

Product Introduction

Thank you for your purchase of the RecPro Gas Range! Before the use of your new RecPro Gas Range, please review this user manual carefully. This user and instruction guide contains useful information pertaining to safety, maintenance/upkeep, installation, functions, features, and warranty.

Please do not dispose of this user manual, as you may need to refer to this guide in the future. If you should ever need to pass this user manual to any future owner of the gas range, please do so. Following the information in this user manual could reduce the risk of injury and will provide information for safe use.

If these instructions are now followed in any way, RecPro does not accept any responsibility for injury or damage.

Safeguard Measures

⚠️WARNING: This symbol indicates a safety alert. It will alert you to possible hazards that can cause serious bodily harm, property damage, or even death. The safety symbol will precede important messages about safety.

WARNING: If one does not follow the instructions in this guide exactly, an explosion or fire may result in personal injury, property damage, or even death.

Do not use or store flammable substances or liquids, such as gasoline, near this product or any appliance.

IN THE EVENT THAT A GAS SMELL IS PRESENT:

- Do NOT attempt to ignite or light ANY appliance or incendiary device.
- Do NOT touch ANY electrical switch.
- Do NOT use any phone or electrical device in your recreational vehicle.
- Evacuate the recreational vehicle of all occupants and pets.
- Shut off the main gas supply or gas tank supply valve.
- From a location away from the gas smell and recreational vehicle, call your gas supplier immediately for further instructions.
- If your gas supplier can not be reached, proceed to call the local fire department or 9-1-1 immediately.
- Have the gas range and system checked and have the leakage source solved by a qualified installer, manufacturer or dealer, the gas supplier, or service agency.

Caution

Hazards or unsafe practices can result in minor personal injury or harm.

Read the following instructions carefully before attempting to use the following application to prevent the potential risk of electric shock, fire, damage to the appliance, or personal injury. Please use the appliance only for its intended purpose as described by this manual.

If you are using an external electrical source, please ensure that the appliance is electrically grounded in accordance to state or other codes, such as the National Electric Code (NFPA70/AN51). Do NOT attempt to repair, adjust, service, or replace any parts on your appliance unless specifically recommended by this manual. Other services should be referred to a qualified service technician.

The warning and important safety instructions appearing in this guide are not meant to cover every condition and possible situation that may occur. Caution, common sense, and care must be practiced when maintaining, operating, or installing your appliance. One should always contact the manufacturer about conditions or problems you do not understand.

INSTRUCTIONS FOR SAFETY

- Do NOT overload the oven door as it could tip the appliance over.
- Remove all tape and packaging before using this appliance. Properly dispose of the carton and plastic bag after unpacking the appliance. Never allow children to play with the packaging material.

- This appliance should be installed properly by a qualified technician, in accordance with local and state regulations and laws.
- Never modify or alter the appliance by removing screws, anti-tip brackets, leveling legs, panels, or any other part of the product.
- Do not use the oven or warmer drawer for storage.
- Do not store objects that could be of interest to children in the cabinets above the appliance. A child could attempt to climb onto the appliance to reach these items and could be harmed or seriously injured.

WARNING

Do NOT use this range as a space heater to warm a room, as this may cause carbon monoxide poisoning and overheat the oven.

Do NOT cover the rear vent on the range, the internal cavity holes, or cover the space at the bottom of the oven door. Never cover the rack completely with materials like aluminum foil or any other flammable objects. Doing this can cause an air flow block; carbon monoxide poisoning, fire, or explosions may occur as a result.

- The range must be separated from the gas supply piping system by closing its manual shutoff valve during any pressure testing that is equal to or less than 1/2psi(3.5KPa).
- Do NOT touch surface burners, space near these burners, the oven burners, or any interior surfaces of the warmer drawers or oven.

During and after use, do NOT touch or allow flammable materials, objects, or clothing to touch or come into contact with these areas until they have cooled down. Any burners, surface or oven, may be hot even though flames are not visible. These burners may still be hot enough to inflict burns or injuries.

- DO NOT wear loose fitting or clothing that hangs while operating this range, as these items could catch fire and cause serious injury or property damage.
- When heating grease, oil, or fat, watch it closely. Oils, fats, or grease can catch fire if they become too hot. In the event of a grease or oil fire, smother the fire with the pan lid, use baking soda, a dry chemical, or foam-type fire extinguishers. **DO NOT USE WATER OR FLOUR!**
- The space in which the range is installed should be constructed so that the range is framed in and guarded to prevent space around the range.

WARNING

Gas leaks may occur in the system and result in dangerous conditions. In some situations, a gas leak may not be detectable by smell. Gas suppliers recommend you purchase and install a UL-approved gas detector. These detectors should be installed in accordance with the manufacturers' instructions.

- Do NOT use wet or damp potholders, only use dry potholders.
- Do NOT let the potholders touch hot or heating burners.
- Do NOT use a towel or other bulky cloth in place of a potholder.
- Do NOT heat unopened food containers as the pressure of heat or steam could build-up. This may cause the container to rupture or explode and could cause harm or serious injury.

- Upon storage or disposal of the appliance, please remove the oven door before doing so.

CAUTION: Never attempt to utilize the range during a power failure. During the event the power fails during use, always shut off the oven, as your appliance may turn on unsupervised as the power restores.

INSTRUCTIONS FOR COOKTOP USAGE:

- **Using the correct flame size:** The flame should be adjusted so that it does not reach beyond the edge of your utensils, such as a pot or pan. Undersized utensils may expose a portion of the burner and flame, which may result in the combustion of fabric or clothing if they make contact with the flame. Using correctly sized pots or pans will improve efficiency and safety.
- **Do not use** stove top grills on a sealed gas burner, doing so may cause incomplete combustion, and this may result in carbon monoxide poisoning.
- **Please memorize** the knobs and their corresponding burners which they control. Always place a pan on the burner before starting a flame. Always turn off the burner before removing the pan.
- **Always** turn the knob all the way to the "Light" mark when igniting the range's top burners. Always then check to see if flames are visible, ensuring that the burner is then lit.
- **Do NOT** face pot or pan handles outward. They should always be facing inward but not directly over another flame. This practice can reduce the risk of serious burns, spillage, or even the combustion of flammable items or materials in the event there is accidental contact with the handle.
- **Do NOT** leave the range's top burners on a high heat setting unattended. Failure to supervise can result in a boil over, which can cause smoke or a grease fire.

- **Protective Sheets:** Never use aluminum foil to cover the oven bottom or burner pans, unless suggested by this manual. The improper use or installation of these sheets and liners can increase the risk of electrical shock or fire.
- **NEVER use a searing grill on the cooktop:** Searing grills are not designed for use on this range. The utilization of a searing grill can cause a fire.
- **NEVER use a decorative burner cover:** In the event that a burner is turned on accidentally, the covers could become too hot, could possibly melt, or combust. This can also result in damage to the range from overheating and can cause ignition and combustion problems.
- **Cooking utensils that are glazed:** Please only use certain types of ceramic, glass, or glazed utensils that are designed for use on a cooktop. Avoid the use of these utensils when possible.

CRITICAL INSTRUCTION FOR OVEN USE:

- **Take caution when opening the oven door when the oven or warmer drawer is in use:** Upon opening the oven door, stand to the side of the range instead of facing directly toward the range. Let all steam or hot air exit before you proceed to replace or remove food.
- **Do NOT obstruct oven vent ducts:** The vent for the oven is located at the center rear of the cooktop. Making contact with the surface in this area while the oven is in use could cause potential burns or serious injury.
- **Never move oven racks when the oven is hot:** Please only move oven racks when the oven is cool. However, If a rack MUST be moved while the oven is in use please exercise extreme caution. Use potholders and grasp the oven rack with both hands. Never allow potholders or yourself to come into contact with the heating elements in the warmer drawer or oven. Always remove all utensils and items before attempting to move the rack.

- **Always use a broiler pan with an insert:** The broiler pan insert allows dripping oil and fat to drain away from the broiler.
- **Never cover the broiler insert with aluminum foil:** Grease and fat could ignite and catch fire if exposed.
- **Never touch the interior of the oven or heating elements:** The oven's heating elements, despite being dark in appearance, could be very hot and could cause burns or serious injury.
- **Never touch any areas on or near the vent panel (back of product):** The vent panel may be hot during use, and could cause burns.

Cleaning Instructions

You should always clean your range regularly and keep all parts grease free to prevent fire. Clean all grease filters and exhaust fan vents. Never allow grease to build up on the filter or hood, grease buildup could ignite. Turn on the hood fan when cooking under the hood.

INSTALLING YOUR APPLIANCE

The installation of your range **MUST** conform with state or local laws and codes. In the absence of codes and laws, please use the standard for RVs (NFPA 1192/AN51).

WARNING

When installing this range, you must adhere to the written instructions in this guide. No representative, agent, or employee of the manufacturer of RECPRO, or any other person(s) has authorization to do any kind of modifications, provisions/edits, or changes to the instructions mentioned in this user manual.

CABINET SPECIFICATIONS

To ensure proper operation of your range, suitable cabinets must be used.

Cabinet specification information:

- There must be a ventilation hole in the cabinet for air circulation. A minimum 3/8" gap at the bottom of the oven will also provide proper air circulation.
- The minimum vertical distance from the cooking top is 30". To reduce the required distance use non-combustible materials and construction. The minimum distance from the top of the cooking grate to the bottom of the non-combustible is 19.5".
- If cabinets are installed above the cooktop, the maximum depth is 13". If the range hood is below the cabinet, there is no limitation for the cabinet depth.
- The minimum distance between the vehicle/trailer floor and the bottom of the cut-out is 4".
- The minimum horizontal distance from the rear wall will be no more than 9" adjacent to the vertical combustible wall.
- The minimum horizontal distance from the side wall will be no more than 7.25" adjacent to the vertical combustible wall.

- All measurements are distances from the center of the burner, out.

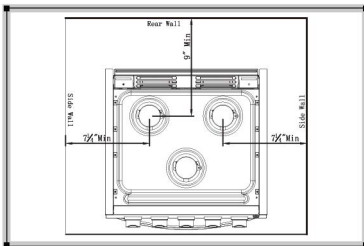

Cabinet and counter cutout:

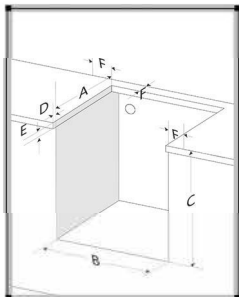

Model	A	B	C	D	E	F
17"RV Range	17.75" 451mm	20.25" 514mm	16.12" 410mm	0.94" 23mm max.	1.56" 40mm max.	2" 51mm min.
21" RV Range	17.75" 451mm	20.25" 514mm	20.06" 510mm	0.94" 23mm max.	1.56" 40mm max.	2" 51mm min.
Above is the minimum cutout size						

How to Install Gas Range Oven:

Once the gas line is in place and the cabinet has been prepared in accordance with the dimensions previously provided:

1. Remove packing material, tape, and any temporary labels from your range, and unscrew the 4 screws marked on (Fig. 1).

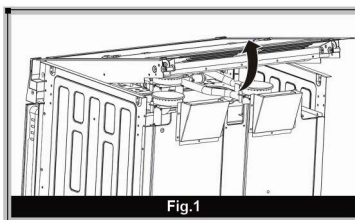
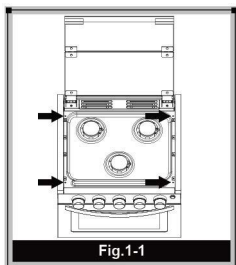

2. Slightly push back the top glass cover assembly and lift up to remove it from the range oven (Fig. 2).

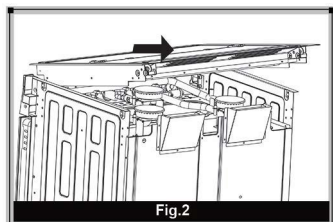

3. Slide the range oven into the cabinet cavity. Verify that the oven is level by using a "Level" tool. Confirm the oven is level rear to front and side to side (Fig. 3).

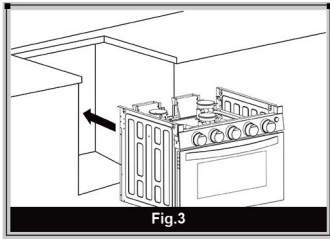

4. Use any approved gas supply tube or hose with proper fitting to the range oven through the gas cavity on the upper left-rear corner of the cabinet. Connect a 12V power supply wire to the appliance from the upper right-rear corner of the cabinet (Fig.4).

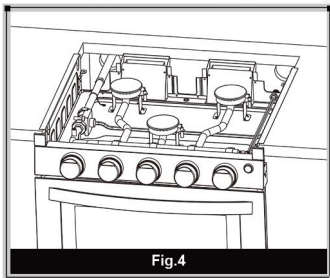

5. To secure the range oven, use two self-tapping screws on both the left and the right (Fig. 5).

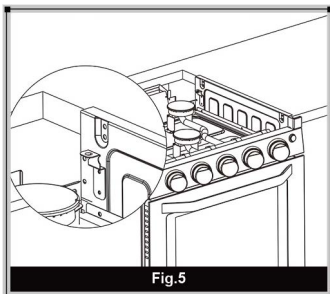

6. Check the pipe fittings for leaks using a soapy solution. **NEVER TEST FOR LEAKS WITH OPEN FLAMES!**

7. Install the top glass assembly as directed by the arrow.

Tighten the screws marked in the picture Fig.1-1.

(Fig.6-1, The holes on the left and right sides of the inside door frame are optional for mounting and do not require screws to be used.)

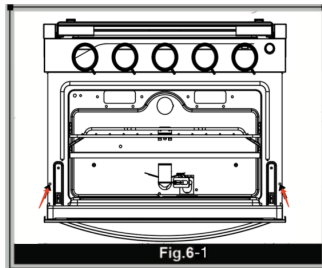
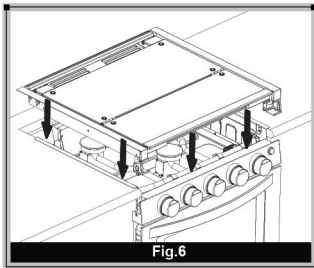

8. Installation is now complete. (Fig. 7)

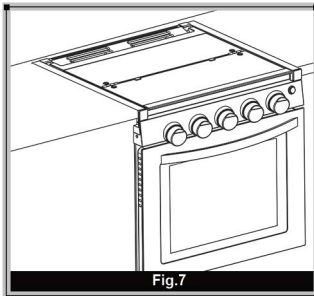

ELECTRICAL CONNECTION:

Range Oven without Light Eliminating Diode (LED) lighting: Attach the wires of the oven and lamp to a 12V DC circuit with a fuse protected and a max rating of no more than 5 amps.

Note: Make sure to connect the wires with the correct polarity.

Black = + (positive)

White = - (negative)

Range Oven with Light Eliminating Diode

(LED) lighting: Attach the light wires to a 12V DC circuit with a fuse protector and a max rating of no more than 5 amps.

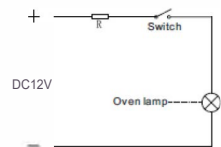

Wiring Diagram

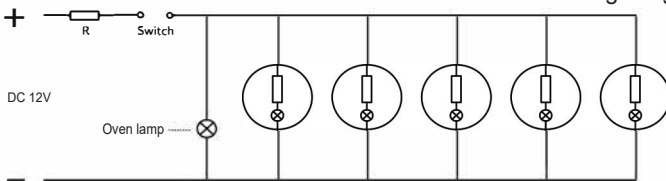



Wiring Diagram

Function

Lighting Oven with Match

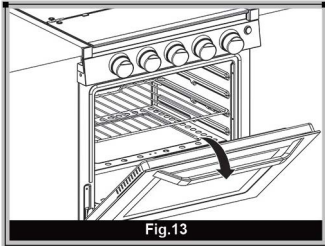
1. Make sure and check that ALL knobs are turned to the OFF position before lighting with a match.
2. Ensure the main gas valve is is in the open position.
3. Open the gas range oven door. (Fig. 13)



4. Push and rotate the oven control knob counterclockwise to  position. (Fig 14)

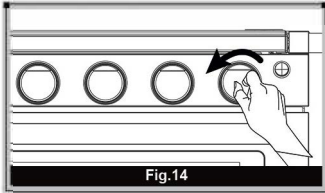

5. While holding and pushing in the oven control knob, open the gas range oven door and insert an extended wooden match or an extended butane lighter through the grate spaces, near the ports of the burner, to light the oven burner. (Fig. 15)

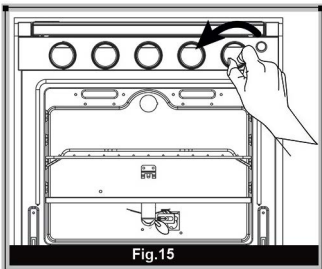

6. Do not let go of the oven control knob, keep the oven control knob pushed in and hold the oven control knob in for 5 seconds after the pilot light is lit. If needed, repeat steps 4 and 5 if the gas range oven is not lit.
7. Adjust the burner to the desired flame level by rotating the oven control knob left and right. (Fig. 16)

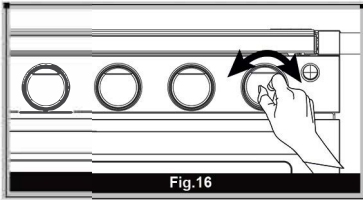

Lighting Electronically:

1. Make sure and check that ALL knobs are turned to the OFF position before lighting.
2. Ensure the main gas valve is in the open position.
3. Push and rotate the oven control knob counterclockwise to the light position. (Fig. 14)
4. Continue to push and hold in the oven control knob for 5 seconds and rotate the ignition button clockwise repeatedly until the burner lights. Repeat steps 3 & 4 if not lit. (Fig. 17)
5. Adjust the flame to the desired level by rotating the control knob.

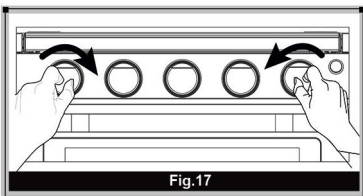

How to Light TOP Burners:

WARNING

The top cover must be open when the main burner is in operation.

Based on safety considerations, the top burner flame size should be adjusted so it does not extend beyond the edge of the cooking utensil.

Lighting TOP burner with a match:

1. Make sure and check that ALL knobs are turned to the OFF position before lighting with a match.
2. Ensure the main gas valve is in the open position.
3. Rotate the appropriate burner knob counterclockwise to the "HI" position. (Fig. 9)

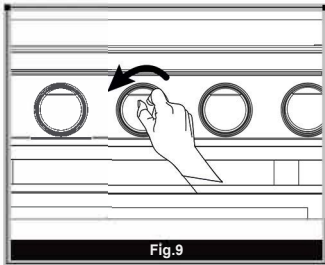

4. PROMPTLY position an extended-lit wooden match, or use an extended butane lighter, through the grate spaces, nearest the burner port, to light the burner. Repeat steps 4 & 5 to light desired burners. (Fig. 10)

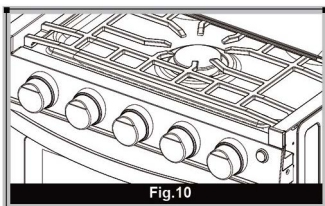

5. To adjust to the desired flame, push and rotate the burner control knob. (Fig. 11)

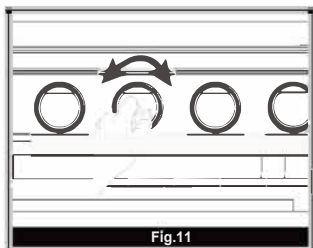

Igniting Gas Range Electronically:

1. Ensure all control knobs are in their OFF positions.
2. Ensure the main gas tank valve is open.
3. Turn the desired control knob counterclockwise to the "HI" setting, DO NOT LIGHT more than one burner simultaneously.
4. Immediately after the control knob is set, turn the ignition knob clockwise multiple times or until the burner lights.

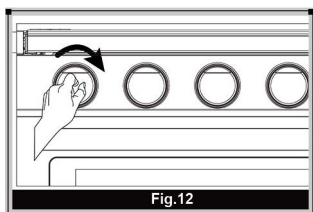

Turning the gas range flame OFF:

To turn the oven or burner flame off, push and turn the control knob clockwise until the knob is in the OFF position. If you travel and need to refuel your gas tank, ALWAYS turn the tank valve off.

Useful information on proper flame for burner: Gas burners will tend to burn blue if the ratio of fuel to air is adjusted properly.

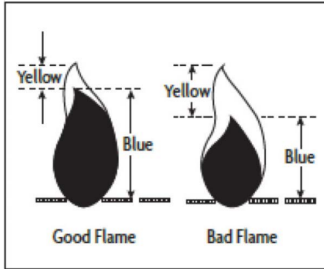

Burner flames that burn yellow on the tip of the flame (over 1 inch) are a sign that the burner is not receiving enough air for the combustion of gas. If the tip of the flame is more yellow in appearance this could indicate that the burners,

air shutter (or Venturi) needs to be adjusted so that it can produce more air. Please be aware of any carbon or soot deposits that may build up on the burner as this too will affect the burner's ability to cook evenly and properly.

This Gas Range oven comes with an LED light feature! Simply press the button to turn the oven LED light on and off.

ALWAYS PERFORM A GAS LEAK CHECK BEFORE USING THE GAS RANGE!

Before operating the gas range, always perform an analysis or check for a gas leak. DO NOT use the gas range until the leak test is performed and confirms there are no gas leak indications. Test for leaks by using between 11-13.8 WC pressure.

- If there is a gas leak detected, replace the defective part recommended by the manufacturer or tighten the loose joint properly.

WARNING

BEFORE TESTING FOR GAS LEAK

1. Ensure gas range controls are in their OFF positions.
2. Never test for leaks with any open flames present.
3. Do not smoke when testing for gas leaks.
4. Use a soapy solution to detect gas leaks. If there are bubbles present, there is a gas leak.

WARNING

MERCHANDISE HARM RISK!

- If the control knob is set to the LIGHT position, DO NOT COOK as damage may occur to the ignition module and the burner electrodes.
- DO NOT LET children or pets play near, at, or around the gas range. Be cautious as the range can tip/fall if pulled. ALWAYS check the oven before setting the oven temperature.
- DO NOT USE cookware that exceeds 1 inch larger than the burner grate. If oversized cookware is used, this may cause extreme heat build-up and may result in destruction to the burner grate, burner, and/or cooktop (maximum pan size= 10 inches).
- DO NOT USE any cooking pan, griddle, or any cooking instrument that covers more than one burner at any time. The maximum pan size is a 10-inch skillet. Any cooking instrument larger than 10 inches is strictly prohibited. If this instruction is not followed, results may cause large amounts of heat that could result in damage to the item or could result in damage to the burner grates or range top.
- Leaving an empty or dry cooking utensil on a hot burner could result in damage to the cooking utensil or could result in serious damage and/or fire. Remove all pans/ cooking utensils, when not in use.

Cooking Tip

Preheat the oven for 15 minutes before placing food to bake.

Range Features

Optional Power	Gas power
BTU/HR	Left and Right Burner: 6500BTU
	Front Burner: 8000BTU
	Oven: 7100BTU
Fuel/Power	Propane
Inlet Pressure	10" WC Min to 13.8" WC Max
Power Input	12V DC<2Amp
Inner Volume of the Oven	17" Range Oven: 35L
	21" Range Oven: 51L

1	Glass Cover
2	Grill
3	Ignition Knob
4	Oven Door
5	Top Burner Control Knob
6	Oven Control Knob
7	Back light
8	Burner

This appliance conforms to the directive:

ANSI Z21.57-2010 Recreational Vehicle Cooking Gas Appliances.

ANSI Z21.57a-2012 Addenda to Recreational Vehicle Cooking Gas Appliances.

CAN1-I.16-M79 (reaffirmed 2016) Propane Cooking Appliance For Recreational Vehicles.

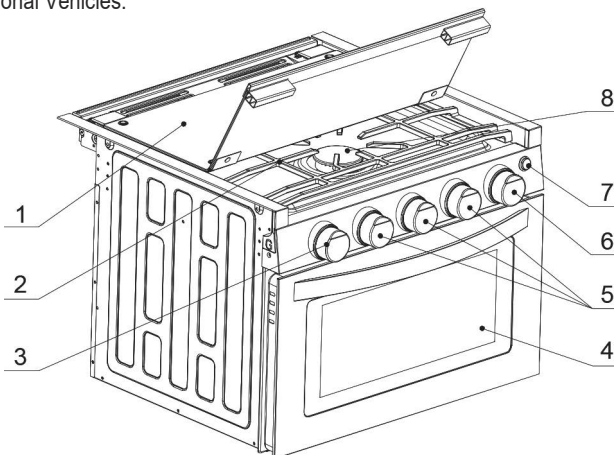

Product Troubleshooting

PROBLEM/SYMPTOM	POSSIBLE CAUSE/SOLUTION
Area surface burners will not ignite or area surface burners do not ignite uniformly	Surface control knob has not been fully rotated to the LIGHT position.
	Check to see if gas valve is open. If not, open it.
	Burners are clogged. Make sure burner is off. Use a small wire, toothbrush or needle to clean burner ports and slots.
	Low gas level in tank. Refill or replace gas tank.
	Low battery power. Replace AAA battery which is under igniter cap.
	There is moisture on the burner. With burner off, dry burner thoroughly.
Surface burner flame is yellow or orange instead of blue	Debris may be present in gas line. Let burner run for a few minutes to see if flame changes to blue.
	Humid air in the home, sometimes caused by running a humidifier, may cause flames to be burn yellow.

Sanitation & Upkeep

- Ensure all control knobs are in the OFF position before cleaning.
- Ensure the cooktop and all components relating to the gas range are cooled off before touching or cleaning.
- When cleaning the oven, only use an oven cleaner specifically designed for ovens. Ensure proper usage of the oven cleaner by following the instructions of the cleaner thoroughly.
- If there is a spill on the gas range, cook-top, grate(s), burner caps, or any other component of the gas range, clean the spill right away (make sure the range is cooled off) as leaving any spill can result in the discoloration or staining of your range or stainless steel.
- Always use caution when cleaning, especially around the burners. If caution is not used, you may catch the metal igniter electrode on your cleaning item (such as your sponge or washcloth, etc.), which can damage or break the metal igniter electrode. If the metal igniter electrode is damaged, the igniter may not ignite.
- If you wish to clean or wash porcelain surfaces, you must allow the areas to cool beforehand. Hot porcelain can crack and can also burn flesh.
- The best way to clean cooktop porcelain surfaces, stainless steel surfaces, painted surfaces, burner grates, plastic items, or any other items relating to the gas range is to use a mild soapy water solution.

THE DO NOT'S OF SANITATION AND UPKEEP:

- DO NOT USE oven cleaners on any surface other than the oven.
- DO NOT USE bleach.
- DO NOT USE rust removers.
- DO NOT USE steel wool, only use non-abrasive pads, such as the soft side of a sponge or a soft washcloth.
- DO NOT USE any abrasive, gritty, or acid-type cleaners.
- DO NOT BLOCK movement of combustion, a.k.a air ventilation.
- DO NOT STORE flammable liquids, vapors (such as gasoline), combustible equipment or materials near, at, or around the gas range.
- DO NOT USE any metallic or wire brush to clean any components relating to the range oven. Some wire or metallic brushes lose their bristles, and these bristles could get stuck in the burner ports or other small crevices and could result in an explosion or a fire.
- DO NOT ALLOW food that contains acids such as vinegar, citrus juices (lemon, lime, grapefruit, etc.), tomatoes, etc., to remain on any painted, porcelain, cooktop, grates, or any other surface relating to the gas range. Some acids react to the paint and gloss that is used. If an egg spill should occur, clean the egg spill when the cooktop has cooled down. Do not allow the egg spill to remain on the surface.

Exploded-View Drawing

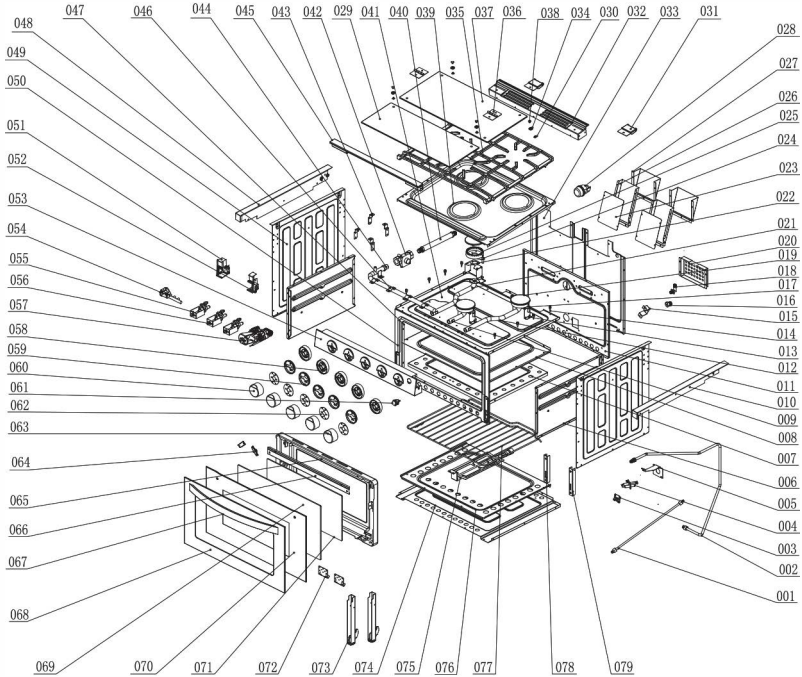

053	Control Panel
054	Igniter
055	Rear Burner Valve
056	Front Burner Valve
057	Oven Thermostat
058	Knob Base
059	Decoration Ring
060	Igniter Knob
061	Lamp Switch
062	LED PCB
063	Knob
064	Door Middle Glass Holder
065	Door Inner Frame
066	Door Inner Frame Holder
067	Door Handle
068	Door Outer Frame
069	Door Middle Glass
070	Door Outer Glass
071	Door Inner Glass
072	Door Glass Holder
073	Door Hinger
074	Bottom Cover
075	Oven Burner
076	Bottom Cavity Plate
077	Bake Rack
078	Door Hinge Holder(Left)
079	Door Hinge Holder(Right)

027	Chimney Holder
028	Viewing Lamp
029	Front Glass
030	ScrewM4X4
031	Hinge B
032	Chimney Decoration Panel
033	Rear Cover
034	Gasket for Top Glass
035	Grill
036	Hinge A
037	Folding Cover Glass
038	Docking Nut
039	Hob Table
040	Rear Gas-In Pipe
041	Insulation Plate
042	Regulator
043	Hob Table Fixer
044	Front Gas-In Pipe
045	Glass Cover Fixer (Front)
046	Gas-In Pipe Holder
047	Front Cavity Plate
048	Left Hob Table Plate
049	Side Cover
050	Door Silicon Sealing Ring
051	Control Panel Holder (Left)
052	Control Panel Holder (Right)

001	Oven Burner Pipe
002	Oven AL Pipe
003	Temp Control Holder
004	ODS
005	ODS Holder
006	Side Cavity Plate
007	Oven Burner Baffle Plate
008	Up Cavity Plate
009	Front Burner Pipe
010	Right Hob Table Plate
011	Rear Cavity Plate
012	Right Burner Pipe
013	Burner Holder
014	Grill Silicon Gasket
015	Nozzle Base Holder
016	Oven Burner Nozzle
017	Rear Burner Ignition Pin
018	Nozzle Base
019	Burner Cover
020	Gas-In Connector Cover
021	Left Burner Pipe
022	Mica Sheet
023	Chimney Cover (Bottom)
024	Front Burner Ignition Pin
025	Fire Distributor
026	Chimney Cover

Product Warranty Information

Your RECPRO appliance is covered by a one-year limited warranty. For one year from your original date of purchase of the original purchaser, RECPRO will pay costs for repairing or replacing any parts of this appliance that prove to be defective in materials or workmanship when such appliance is installed, used, and maintained in accordance with the provided instructions.

Exclusions

This warranty does not cover the following:

1. Products on which original serial numbers have been removed, can not be determined, or altered in any way.
2. Product that has been transferred from its original owner to another party. Product has been removed outside of the USA or Canada.
3. Rust on the interior or exterior of the unit.
4. Products that have been purchased secondhand.
5. Commercial use of product.
6. Service calls which do not involve malfunction or defects in materials or workmanship, or for appliances not in ordinary household use or used other than in accordance with the provided instructions.
7. Service calls to correct the installation of your appliance or to instruct you how to use your appliance.
8. Expenses for making the appliance accessible for servicing, such as removal of trim, cupboards, shelves, etc., which are not a part of the appliance when it is shipped from the factory.
9. Service calls to repair knobs, buttons, handles, or other cosmetic parts.
10. Surcharges including, but not limited to, any after hour, weekend, or holiday service calls, tolls, ferry trip charges, mileage expense for service calls to remote areas, including the state of Alaska.

11. Damage to the finish of appliance, RV, or home incurred during installation, including but not limited to floors, cabinets, walls, etc.
12. Damage caused by services performed by unauthorized service companies, use of parts other than genuine RECPRO parts or parts obtained from persons other than authorized service companies, or external causes such as abuse, misuse, inadequate power supply, accidents, fires, or acts of God.

The customer's sole or exclusive remedy under this limited warranty shall be product or repair or replacement as provided herein. Claims based on implied warranties, including warranties of merchantability or fitness for particular purpose, are limited to one year or the shortest period allowed by law, but not less than one year. RECPRO shall not be liable for consequential or incidental damages such as property damage and incidental expenses resulting from any breach of this written limited warranty or any implied warranties, so these limitations or exclusions may not apply to you. This written warranty gives you specific legal rights. You may also have other rights that vary from state to state.

Proof of purchase may be required for warranty purposes. If service, of any kind, is performed please obtain and keep all original receipts. Product features or specifications as described or illustrated are subject to change without notice.

REC PRO[®]



For further information, please contact:

ICON DIRECT INC
806 S. DIVISION ST. BRISTOL,
IN 46507, USA